

INSTRUCTION MANUAL

Hybrid – BOOST Charge Controller with Wireless Connection

www.silentwindgenerator.com

Congratulations, you have bought a high-quality SILENTWIND hybrid charge regulator HYBRID BOOST

Before using this gadget please carefully read this manual.

General Information

The Silentwind-Charge controller HYBRID BOOST is a combined wind and solar charge regulator with an inbuilt micro-controller. The HYBRID BOOST was especially developed for the Silentwind Generator and enables you additionally to install solar panels up to a wattage of 300 Watt peak or to a max. current of 20A. Consumers with a maximum current of 10 Amps that are connected to the deep cycle output can be automatically switched off or on by a deep cycle protection function.

All operating parameters can be seen on a LCD-display or on a tablet or smart-phone over the Wireless connection. You can also set all operating parameter over the APP provided. It is suitable for all Android and IOS devices.

The Silentwind Generator generates 3phase AC-voltage. In the charge controller AC is transformed to DC voltage. 12 / 24 or 48 must be chosen in accordance with the system voltage of the customer. All types of batteries (Gel, AGM, acid and Lithium) can be charged.

The suitable maximum charge voltage - depending on the type of battery - must be adjusted in the Setup.

The charger controller is **CE** approved.

Advise

Please keep in mind that liquid acid batteries can emit dangerous explosive gas. If the place where you mount the charge controller is close to these batteries, ensure efficient ventilation. Gel or AGM batteries are normally maintenance free and do not emit gas if properly charged.

Always make sure charge controller is mounted in a dry and as cool as possible place.

Contents

1.	Wiring diagram	5
2.	Technical data	6
3.	Components of the charge controller	7
3.1.	Bottom panel	7
3.2.	LCD	7
4.	Mounting the charge controller	8
5.	Cable size selection	8
6.	Installation and connection of the charge controller	9
7.	External Stop Switch	10
8.	Connecting solar panels	10
9.	Programming charge controller	11
10.	Programming instruction	12
10.1.	SilentWind Controller APP installation and operation	12
10.2.	Settings	12
10.2.1	Settings parameters	13
10.2.2	Charging – Absorption mode	13
10.2.3	Break adjustment	13
10.2.4	Boost function	14
10.2.5	Charge cut-off voltage	14
10.2.6	Save settings	14
11.	Troubleshooting	15

1. Wiring diagram

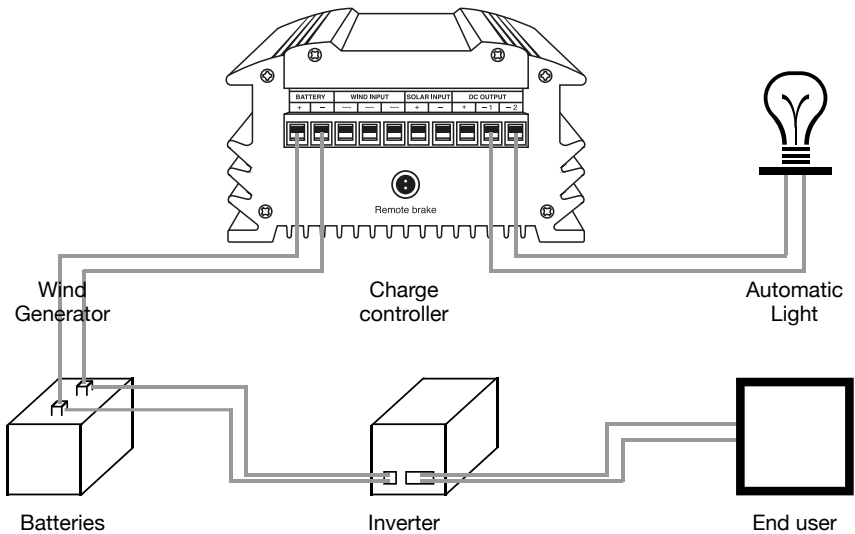
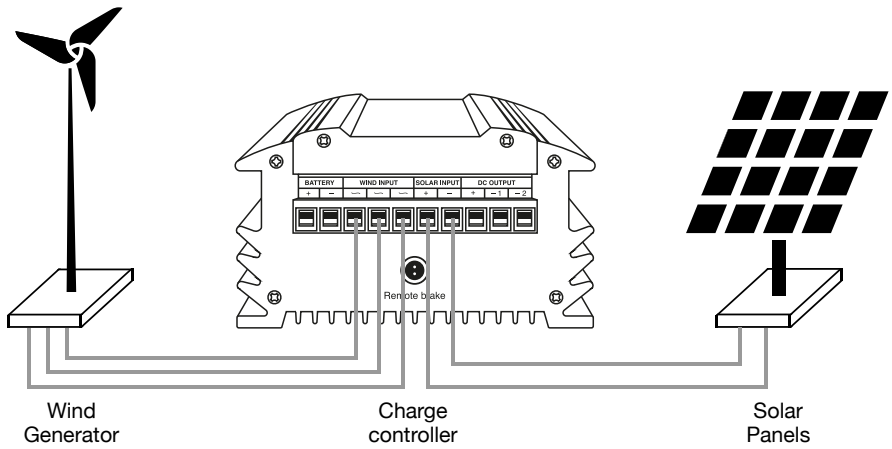

2. Technical data

Hybrid-charge controller type	HYBRID BOOST
Battery system voltage (automatically detected)	12 / 24 / 48 Volt
Max. power input of the wind generator	600 W
Max. current input of the wind generator	40A / 30A / 15A
Max. power input of the solar panel	300Wp
Max. current input of the solar panel	20A / 10A / 5A
Max. open circuit voltage input of the solar panel	50VDC
Max. total charge current	60 A
Max. switch off current at LOAD-output (Load)	2 x 10 A
Max. voltage adjustable for the battery types	acid, gel or AGM
Dimensions (L x W x H) in mm	220 x 150 x 82
Weight	2,80 kg
Suitable for	flooded, sealed, gel or AGM
Warranty	24 months

Features

Cable connection	screw terminals
Integrated electronic brake	charge limitation, storm brake
Integrated manual brake switch	service
LCD-display of all relevant working data	W, A, V/Ah, kWh, Ah
External stop switch	Plug connector

3. Components of the charge controller

3.1. Bottom panel

On the down side of the charge controller there are screw terminals to connect the battery, the wind generator, the solar panels and DC consumers.
The connections for the remote brake are also below.



3.2. LCD

On the top of the charge controller there is an LCD-display that shows you all operating data during the working process.



4. Mounting the charge controller

The charge controller generates heat and should be mounted with the panel upright (if you can read the front panel text horizontally then this is correct). The side panels and back panel are a heat sink to dissipate heat, which is why the orientation is important.

The charge controller is mounted to the wall using four screws.

5. Cable size selection

As you can see from the wiring diagram in paragraph 1 a 3-pole cable with suitable cross section must be wired from the Silentwind-Generator to the charge controller. The charge power gets from the charge controller to the batteries through two wires (on the AC entrance through three wires) Therefore the cross section of the two wires on the DC output should be larger, we recommend a minimum cross section of 10mm².

See below table to find the correct cable cross section:

System voltage 12 Volt

Distance from wind generator to the charge controller in m	0 - 9	10 - 19	20 - 29	30 - 44	45 - 69	70 - 110
Cable cross section mm ² AWG	6 - 10	10 - 8	16 - 6	25 - 4	35 - 2	50 - 1
Distance from the charge contr. to the battery in m	0 - 9	10 - 19	20 - 29	30 - 44	45 - 69	70 - 110
Cable cross section mm ² AWG	16 - 6	25 - 4	35 - 2	---	---	---

System voltage 24 Volt

Distance from wind generator to the charge controller in m	0 - 9	10 - 19	20 - 29	30 - 44	45 - 69	70 - 110
Cable cross section mm ² AWG	2.5 - 14	4 - 12	6 - 10	10 - 8	16 - 6	25 - 4
Distance from the charge contr. to the battery in m	0 - 9	10 - 19	20 - 29	30 - 44	45 - 69	70 - 110
Cable cross section mm ² AWG	16 - 6	25 - 4	35 - 2	---	---	---

6. Installation and connection of the charge controller

The charge controller should be mounted close to the battery in a ventilated and cool location which enables you to read the information shown on the LCD display and to operate the manual brake switch easily. There is a remote brake switch can be used if the charge controller is not easily accessible.

Safety device:

Especially acid batteries can emit gas when charging. Therefore the charge controller must not be installed close to those batteries. In case of high concentration of dangerous gas there is a risk of explosion. Please note the safety regulations, advice of the battery producer.

If the acid batteries are equipped with ventilation pipes to the exterior or if the storage room of the batteries is otherwise ventilated, the charge controller can be installed close to the batteries.

Please find a sketch of the wiring diagram in the paragraph 1 of this manual.

Make sure that you fix the wires properly to prevent them from getting loose due to vibrations. Fix the screws sufficiently to ensure electric contact.

Connect the free end of the wire with your wires coming from the wind generator and the battery with suitable insulating screw joints.

In case you do not use the connecting wires we recommend the use of crimp type cable sockets to fix your wires directly to the charge controller. After having fixed the crimp type cable sockets with the bared wires these can be fixed to the cable sockets.

It is most important that you first connect the charge controller to the battery with the right polarity.

Please connect a suitable fuse (50Amp. or more) close to the battery in the positive wire.

Please take note:

After the connection of the battery you can connect the Silentwind Generator, the solar panel and if required a load output with maximum 10A. On the 3-phase output wires of the Silentwind you need not to pay attention to polarity.

Attention

The confusion of Plus and Minus will definitely destroy your charge controller. In that case warranty is gone.

If there is sufficient wind speed when connecting the Silentwind Generator, this will immediately generate electric power at the end of the 3 AC-wires without being connected to the charge controller. Therefore we recommend blocking the Silentwind Generator blades with a rope before connecting the wires to the charger. The 3 AC output wires must be connected to the 3 screw terminals on the back of the charge regulator. (See paragraph 3.1). In a 3 phase AC system the connection order / polarity does not matter.

7. External Stop Switch

You can connect an external stop switch to the charge controller (see picture on page 5). You can choose the type of stop switch suitable to your instrument panel.

8. Connecting solar panels

The charge controller Hybrid BOOST is a hybrid controller both for wind and solar energy. Solar panels with a max power of 300 Wp (20 A for 12V / 10 A for 24V and 5 A for 48V) can be connected, See technical details page 4.

Connect the solar panels according to the following sketch.

12 volt system:

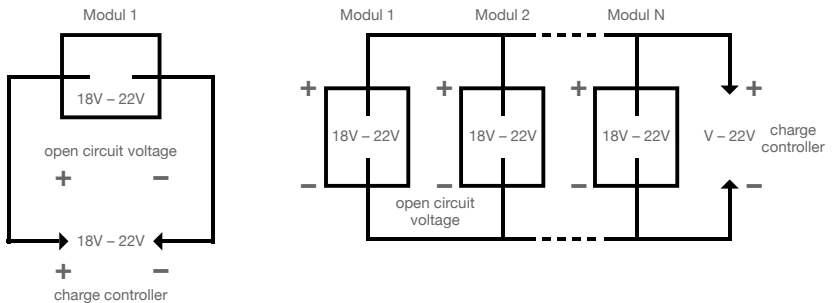

24 volt system:

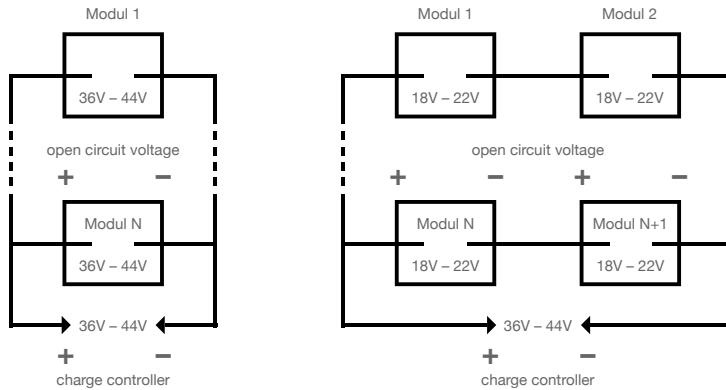

9. Programming charge controller

Before first using the charge controller it must be adjusted to the type of battery (acid, gel, AGM) you want to use, the Storm brake and the absorption modus according to your system.

A special feature of this charge controller is that you can programme everything thru your Smartphone or Tablet. Download the APP for your operating system (Android or IOS) from our website or on the App Store. If the charge end voltage – according to the type of battery – is reached, the charge controller will switch of the Silentwind Generator under step “Over voltage”. Additionally the maximum charge current can be adjusted. You have to programme the requested switch off current at the step “Brake Current”.

We also recommend making use of the additional adjustments according to your individual requirements, like the switch on- and switching off-voltage of the load settings and light function.

If the charge end voltage or maximum charge current is reached, the Silentwind Generator will stop for approx. 5 minutes.

The break mode of the charge regulator generates internal rising temperatures that are thermally detected. Therefore the break time of the Silentwind Generator will be increased in high wind speeds until the internal temperature is reduced by dissipation.

For this reason the charge controller should be installed on a place as cool as possible. Never install the controller at direct solar radiation or sunlight.

This means that the Silentwind Generator can also be operated with a larger battery capacity. If a large battery capacity is discharged, a higher charge current will flow in high wind speeds. As you can set the maximum charge current you can prevent overheating of the charge controller. As described in step “Brake Current” you can reduce the max. charge current according to the requirements.

Advice

If the capacity of the batteries is less than 150 Ah, or old batteries have lost their original capacity, the point of max. Voltage can be reached very fast although the battery is not fully charged yet. In this case it can be useful to connect an electric consumer to the Load-output, as this will reduce the voltage and thus prevent that the break mode is activated too early.

10. Programming instruction

10.1 SilentWind Controller APP installation and operation

The SilentWind Controller APP is available on the Google Play for Android devices and Apple Store for IOS devices.

Go to your app store according the operating system of your phone and search for: SilentWind Controller

Download the app and install it as any order APP.

The Android APP is compatible with Android version 5.0.1 or above;

The IOS APP is compatible with IOS version 8 or above;

After installing the APP make sure Bluetooth is enable in your phone and the controller is on and near your phone.

10.2 Settings



Serial Number 0000000000

Name Device Name

Model 12v

Connect

Open the APP in your device and make sure you find your controller serial number inside the box of the new controller, in a A5 printed page.

The APP will ask you to introduce the serial number, chose a name for your controller (ex: winpower1) and select the correct model of your controller. The APP will find automatically your controller and connect, and you are ready for operate and change setting is your controller.

10.2.1 Settings parameters

Settings	
Battery Settings	
Absortion (V)	13.8 >
End-of-Charge Voltage (V)	14.1 >
Wind Settings	
Low Wind Boost (V)	2 >
Storm Brake (A)	32 >
User Output Settings	
Under Voltage Switch Off (V)	10.8 >
Under Voltage Recovery On (V)	12 >
Solar Switch On (V)	1 >
Solar Switch Off (V)	1.5 >

Go to menu key on your device and then 'Settings'.

10.2.2 Charging – Absorption mode

Battery Settings	
Absortion (V)	13.8 >

In the display mode shown above „Unload Volts“ you can set the absorption modus of your batteries by clicking on the field and change the values. Usually this stage is to slowly keep charging the batteries until the charge end voltage is reached. The values depend on the system voltage (12/24/48V). The approx. values are 0.5% less than the maximum possible voltage. For instance for a charge end voltage of 14.4V (12V system) the value should be 13.4V

10.2.3 Break adjustment

Wind Settings	
Storm Brake (A)	32 >

You can set the current when you want to stop the Silentwind Generator. This prevents overheating, especially with big battery banks and high loading currents. This function can also be used to reduce the RPM of the Silentwind Generator.

You can calculate the max. charge current value as follows: The max. power of the Silentwind Generator 400 Watts divided by the max. cut-off voltage e.g. 14,4 Volt at a AGM battery. The max. possible charge current in this example is $400\text{VA}/14,4\text{V}=27,7\text{Amp}$.

10.2.4 Boost function



With this parameter you can set the Boost to achieve an earlier start of charging in to the batteries. The recommended values are:

12V – 2.0V

24V – 4.0V

48V – 8.0V

10.2.5 Charge cut-off voltage



In the display mode shown above „Overvoltage“ you can set the charge end voltage of your battery. Please note the instructions of the manufacturer of the batteries. The maximum possible voltage is dependent on the system voltage (12/24/48V) and the type of battery (Acid, Gel, AGM or Lithium).

For instance 12V-AGM-Batterie: appr. 14,4V.

10.2.6 Save settings



Click on save data to save the settings.

Safety advice

Please never disconnect the battery wires while the Silentwind Generator is charging. This will immediately destroy the charge controller. If you want to measure the current flowing, an amp-meter must be installed in the positive battery wire. Mind the polarity of the amp-meter. The flowing current can be seen at the LCD-display.

11. Troubleshooting

The blades of your Silentwind Generator are turning too slowly

- The manual stop switch of the charge controller is in position “BRAKE”.
- Connecting the wires possibly caused a short circuit between the wires.
- The wind speed is too low.
- The fuse connected to the battery is gone.
- Your Silentwind Generator or the charge regulator has an internal problem.

Please contact your dealer.

In order to find the mistake you have to check the installation chain starting at the 3 wires of the SilentWind Generator connected to the charge controller. In case the Silentwind Generator does not start (without connection to the charge controller) the failure is between charge regulator and battery. BE CAREFULL, don't touch the end of the cables because of the electric power that occurs at these ends. If the Silentwind Generator continues to turn slowly, the failure is between charge controller and Silentwind Generator.

Mind the recommended cross section of the wire as well as the recommended minimum capacity of the battery that you want to charge.

If the Silentwind Generator generates too little power

- The wind speed is too low, see the performance diagrams shown in the manual of the Silentwind. The wind speed measured on top of the mast is higher than at the position of the wind generator!
 - Turbulences by obstacles in the wind direction or the location is unsuitable, mast too short.
 - The wire cross section is not in line with the length of the wires installed. (see page 3).
 - The battery-capacity is below 100Ah so that the maximum possible voltage is generated too fast.
 - The battery is too old and has lost capacity so that the maximum power voltage is achieved too fast.

Enjoy collecting regenerative power.
You contribute protecting the environment and saving your money !





Rulis Eléctrica, Lda.
Loteamento Industrial de Linhares,
Lote 19 PT-4805-486 Santo Estevão de Briteiros
Guimarães, Portugal

VAT/Contribuinte / EORI-N. PT 502 995 530

Tel. +351 253 572763 | +351 967 907 933
Fax +351 253 572764
info@silentwindgenerator.com
www.silentwindgenerator.com